

Thermal Energy Storage

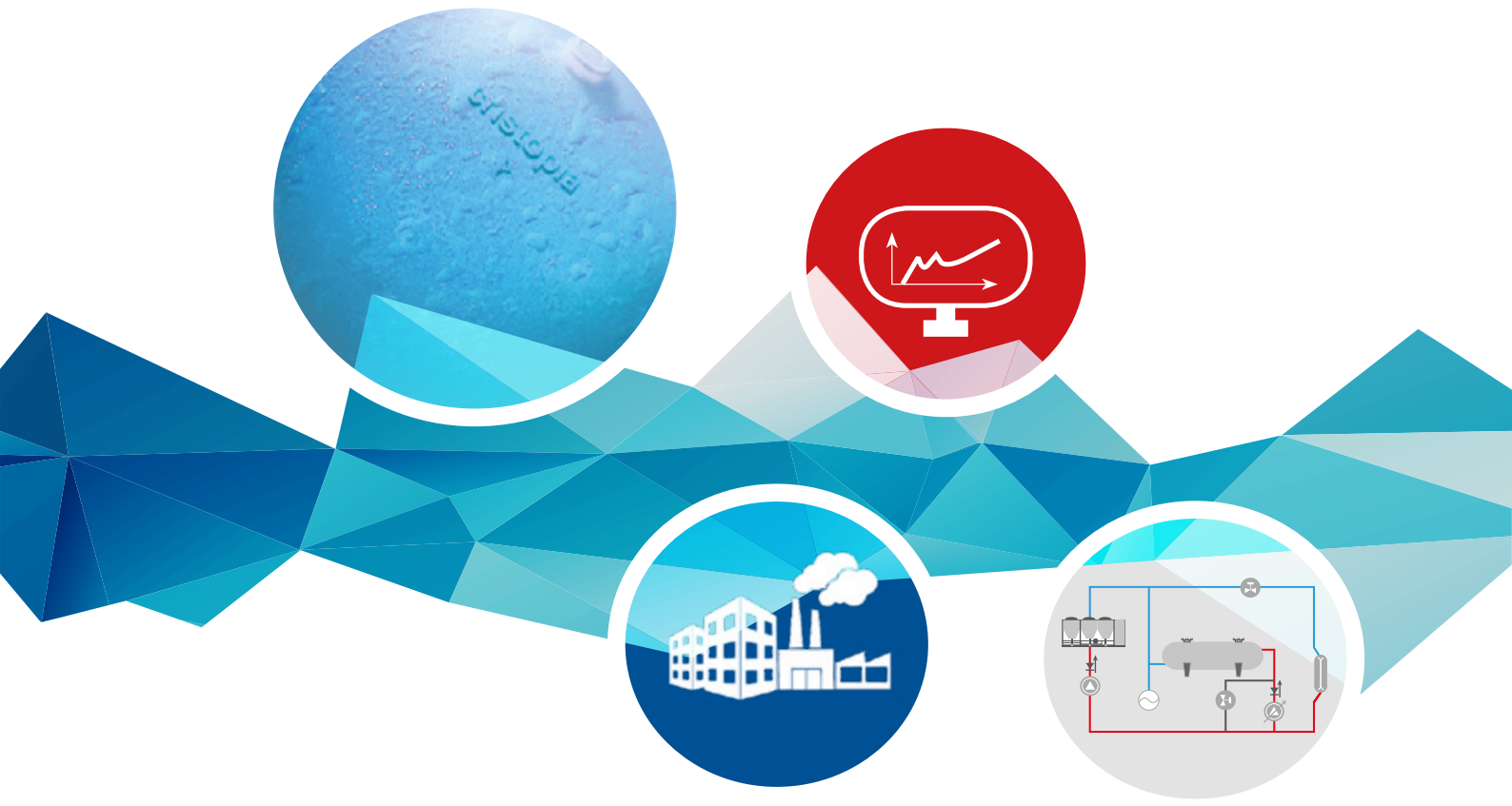

Why a Thermal Energy Storage system?

➔ For cooling centralized installations on water loop

Without storage	With storage	Air-conditioning	Industrial cooling	Rescue facilities
		Reduction of the chiller capacity by 30 to 70%.		
		Peak shaving of the cooling demand over 24 hours.		
		To shift electricity consumption from peak hours to off-peak hours.		
		Reduction of the electricity power by 30 to 70% on the cooling production.		
		Reduction of the electricity costs and the operating costs.		
		Making the electricity consumption profile more attractive for operators.		
		Improving the environmental assessment.		

➔ A key technology for energy demand management

Shaving the cooling production over 24 hours:

- reduction of the chiller capacity by 30 to 70%,
- operating the compressors in steady conditions,
- reliability of chillers and improved global output,
- reduction of refrigerant fluids,
- TEWI* benefits from 15 to 40% (*TEWI: Total Equivalent Warming Impact).

Shaving the electrical demand (load management):

- reduces the electricity power of the cooling production by 30 to 70%,
- promotes the most efficient power plants (base load),
- reduces the peaks on distribution networks and power plants,
- promotes the use of less carbonaceous kWh at night than during the day.

Sustainability of long-term performance:

- simple technology with very long lifespan and without maintenance,
- monitoring and support of CRISTOPIA (Cristo'Control2 & services).

CRISTOPIA is committed to renewable energy and sustainable development through:

- system compatible with smart grids,
- possible coupling with renewable energy (eolian, photovoltaic).

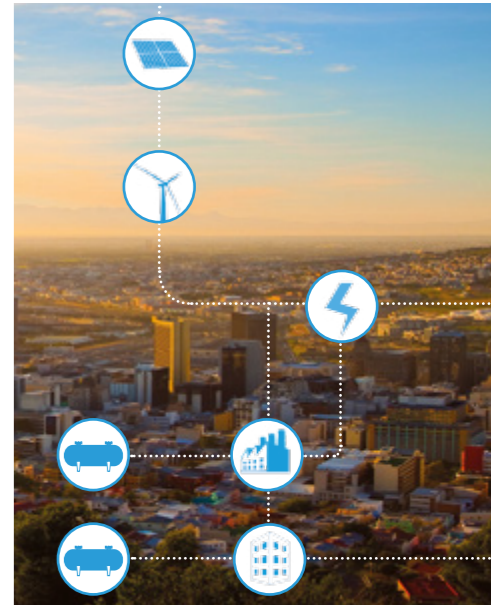

➔ A system approach with made-to measure support

- System engineering in terms of specific needs and customer constraints.
- Full system control which includes other energies optimizing technologies like free cooling or energy recovery for domestic hot water.
- Functional analysis and hydraulic principle.
- Constructor commitment on the operating of the cooling production with a STL.
- Commissioning of the control and monitoring system and remote control follow-up of the installation.
- Training on control and monitoring system.
- Operating optimization and readaptation of the strategy in case of needs evolution.
- Support during the entire storage system lifespan.

➔ A key technology for a sustainable development approach to buildings

Energy optimization of the HVAC system	LEED	BREEAM	HQE
Reduction of the installed and used electricity power thanks to an optimum use of chiller capacity.	X		X
Counting the energy used thanks to the monitoring system that controls and manages the production of cooling energy in the building.	X		
Green energy used by the STL connected to the grid.		X	
Supervising the performance of the HVAC system and the thermal comfort of the building through the monitoring system.	X	X	
Eco-friendly site	LEED	BREEAM	HQE
Reduction of CO ₂ emissions.	X	X	
Reduction of primary energy consumption and associated pollution.		X	X
Reduction of the amount of refrigerants used.	X	X	X
HVAC system reliability and maintenance savings	LEED	BREEAM	HQE
Durability and resistance of the materials used for the production of cooling energy with STL (tank and nodules, use for more than 40 years).	X		X
Optimization of the design of the system for simplified up-keep and maintenance.	X	X	X
Optimization of the operation of the HVAC system that saves on operating costs.		X	X

Thermal Energy Storage, a simple and reliable technology for sustainable energy performance

Histogram of a building's daily cooling needs and its electricity consumption profile

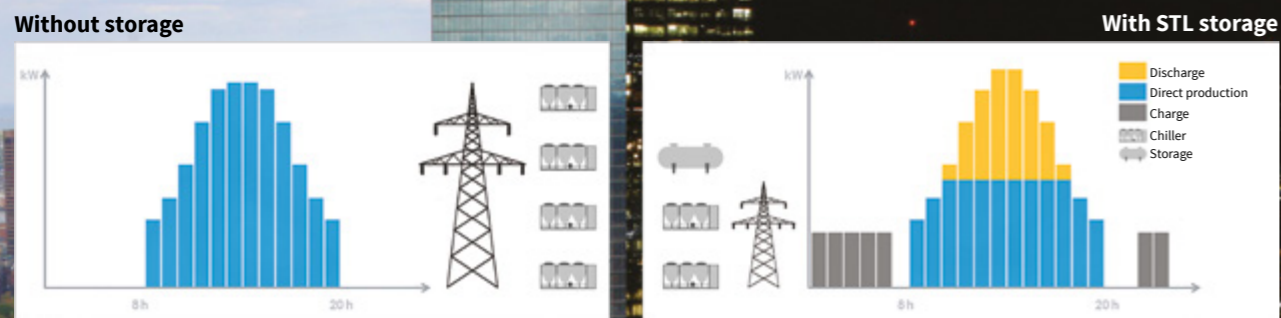

➔ CRISTOPIA: world leader in Thermal Energy Storage

- CIAT Group subsidiary, expert in heating, refrigeration and air-conditioning.
- Headquarters and factory in France.
- Factory in Zhongshan, China (near Hong Kong).
- A proven technology since 1982:
 - thermal energy storage systems,
 - control and monitoring systems.
- More than 3 000 customers worldwide.
- More than 6 000 000 kWh transferred daily.
- More than 500 MW electricity saved.
- International Network thanks to exclusive partners.

The STL technology (Latent Storage)

➔ Nodules inside...

The CRISTOPIA STL is a Thermal Energy Storage by Phase Change Material (PCM) encapsulation. The STL system is composed of one or several tanks filled with spherical elements (called nodules) containing the PCM.

The use of PCM in nodules provides very high energy density and power exchange.

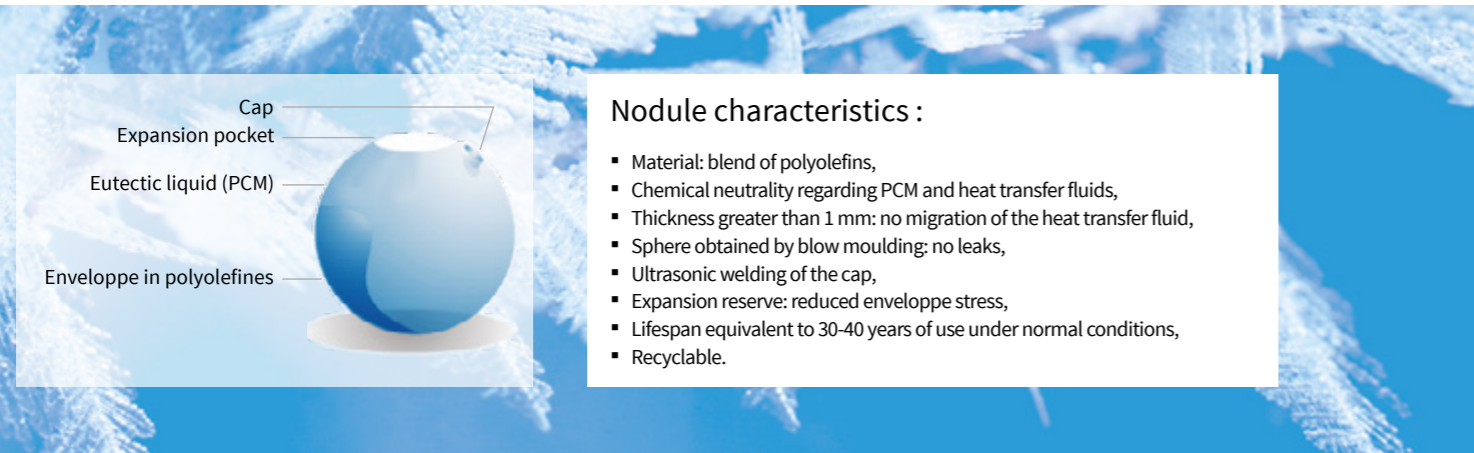

The Phase Change Materials (PCM)

CRISTOPIA has unique expertise on Phase Change Materials (PCM), resulting from over 30 years of R&D in partnership with universities and technical centres in France and Europe.

We have worked on all types of PCM with solid liquid transition over a wide temperature range of -64°C to +140°C: inorganic materials (hydrated salts) and organic materials (paraffins and fatty acids or Bio PCM).

Our expertise covers the PCM (formulation, nucleation, characterization, durability, recyclability, ...), packaging and encapsulation of PCM, the envelope materials (material compatibility, ageing, ...), the industrial manufacturing processes and the engineering of the system.

➔ ...a made-to-measure tank

Sizing and characteristics of the STL tanks are defined in terms of the site and its capacity from 1 m³ to several thousands of m³. The tank may be cylindrical or rectangular parallelepiped (concrete or steel).

The cylindrical tank may be installed inside, outside or underground. CRISTOPIA STL storage offers a full range of integration possibilities inside available spaces.

The filling of nodules in the tank is done through the manholes. The heat exchange between the nodules and the system is ensured by the heat transfer fluid circulating in the tank. Two distributors (upper and lower) distribute the heat transfer fluid in the tank for optimum performance.

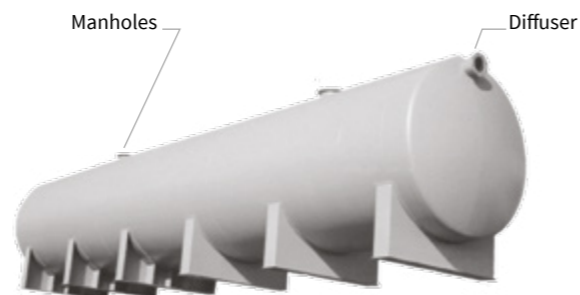

Vertical tank



Horizontal tank



Concrete tank

➔ A technology which combines thermal performances and exceptional lifespan

	Steel tank	Concrete tank
Manufacturing	Classical steel tank manufacturing	Civil engineering
Type / shape	Cylindrical	Rectangular parallelepiped
	Vertical, horizontal or buried	Reservoir
Service pressure	Pressurized or atmospherical	Atmospherical
Advantages	Custom made, factory manufacturing	Big volumes, easy integration to the building



Characteristics for a 1 m ³ STL tank							
Nodules type	Phase change temperature °C	Latent heat Ql kWh / m ³	Sensible heat		Nodules weight Kg	Toxicity value LD50 mg / kg	Temperature limit for use °C
			Solid Qss kWh / °C.m ³	Liquid Qsl kWh / °C.m ³			
AN.15	-15.4	46.4	0.70	1.12	602	8 400	-25°C to + 60°C
AN.12	-11.7	47.7	0.75	1.09	620	5 000	
AN.10	-10.4	49.9	0.70	1.07	617	11 000	
AN.06	-5.5	44.6	0.75	1.10	625	18 000	
AN.03	-2.6	48.3	0.80	1.20	592	58 000	
AC.00	0	48.4	0.70	1.10	560	85 000	

Operating principles

Hydraulic layouts

The choice of the hydraulic layout depends on the application, the operating conditions and the specific needs of each customer. We assist the consulting engineers in adapting the hydraulic layout to each project, by integrating where necessary complementary technologies such as free cooling or energy recovery.

The hydraulic layouts presented below are simplified to explain general operating principles of installations with Thermal Energy Storage systems.

Applications for residential, commercial or industrial buildings with a difference of return / leaving temperature of less than 8°C

The parallel layout with variable flow or parallel with a 3-way valve (3WV) are used for installations operating with less than 8°C ΔT , i.e. in air conditioning systems with a 7/12°C regime.

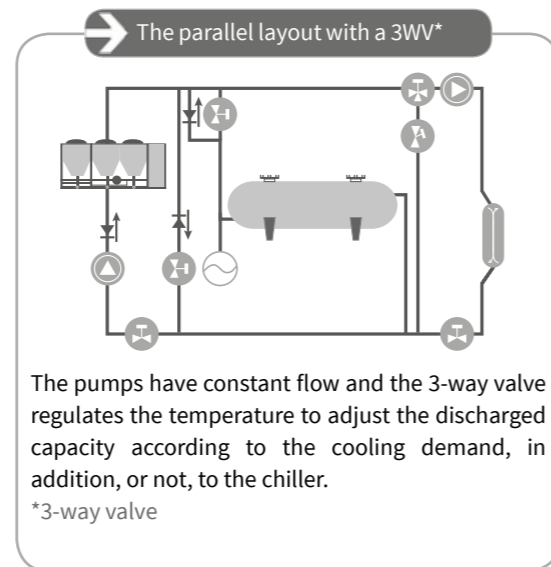
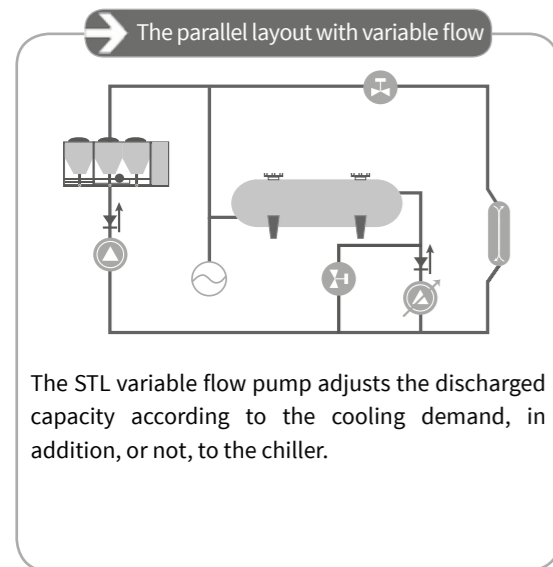

Applications with a temperature difference return / leaving of more than 8°C of the type district cooling system or industrial process

Downstream and upstream series layouts are used for installations operating with more than 8°C ΔT , for example in district cooling systems with a 4/14°C regime.

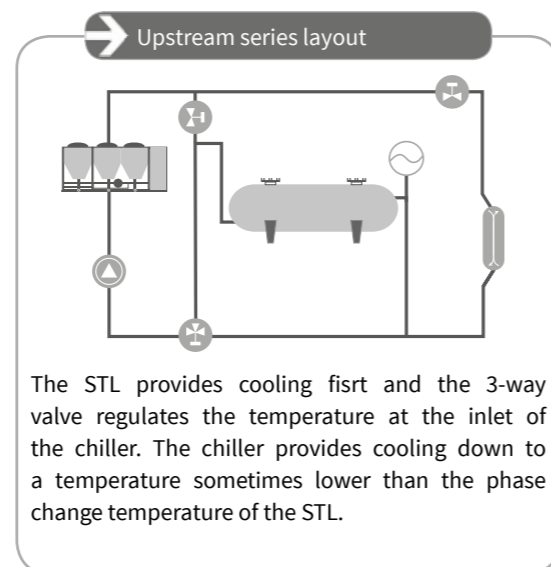
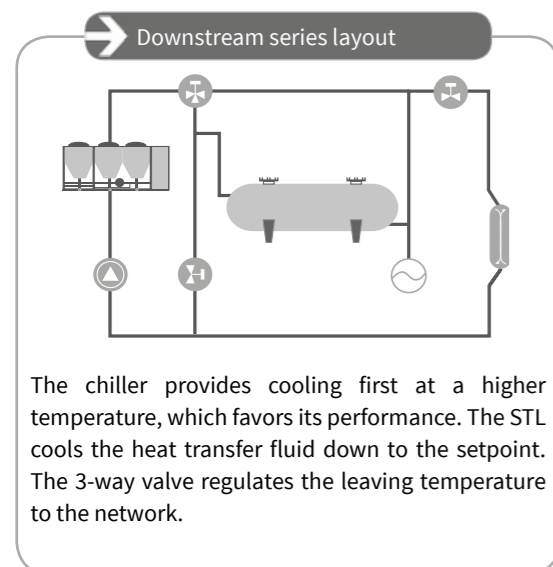

Simplified functional analysis - Example of the parallel layout with variable flow

Charge only

Overnight the chiller is used to store cooling energy in the STL. The heat transfer fluid is cooled by the chiller to a temperature below the phase change temperature of the PCM.

Circulating the heat transfer fluid through the tank causes the crystallisation of the PCM contained in the nodules.

The latent energy is stored at a constant temperature during the liquid-solid transition.

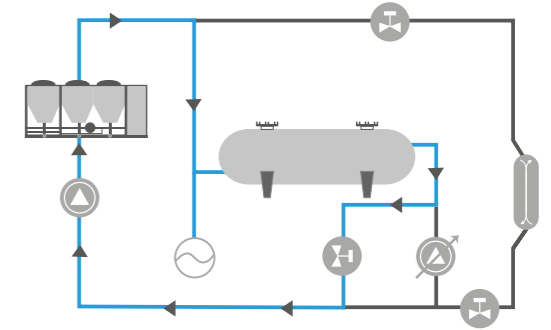

Direct production

When the cooling demand is lower than the installed chiller capacity, the demand is satisfied by the chiller alone.

The chiller capacity is regulated according to the demand.

There is no flow through the STL.

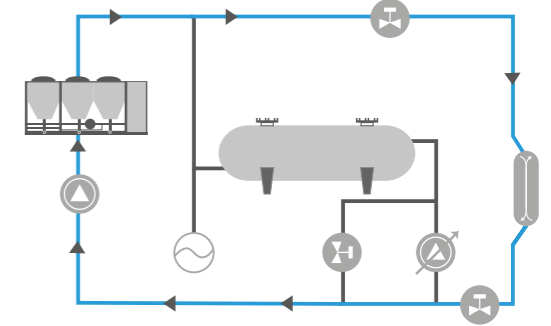

Discharge only

The STL can be used alone during peak electrical tariff periods or for back-up applications (the chiller being off).

The heat transfer fluid enters the STL at a temperature higher than the PCM melting temperature and is cooled by the nodules.

The leaving temperature is controlled by the 3-way valve to match the system demand.

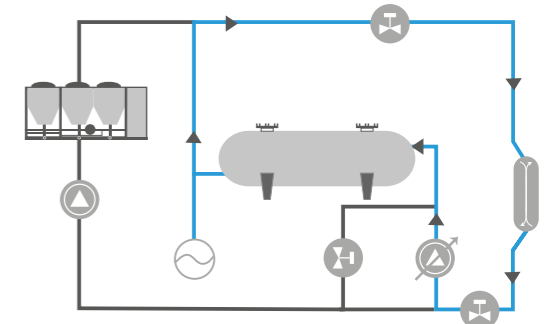

Direct production + discharge

When the system demand is higher than the installed chiller capacity, the cooling energy is provided by the combined efforts of the chiller and the STL.

The chiller works at full capacity and the STL provides the short fall.

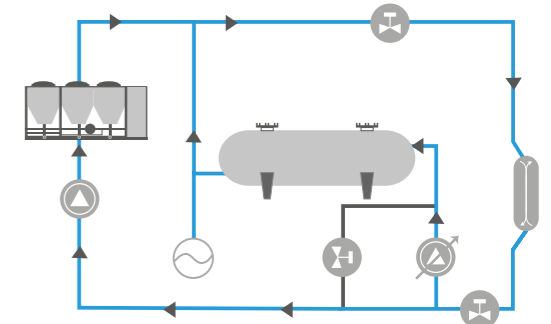

Control and monitoring system

Advantages of the Cristo'Control2 for your installation

The control and monitoring system optimises the operation of the installation. With over 30 years of experience in storage and control systems for air-conditioning and industrial cooling, CRISTOPIA offers customized solutions dedicated to your needs.

The Cristo'Control2 helps contractors and owners to optimise energy consumption, to lower the CO₂ and greenhouse gas emissions and to reduce operating costs.

Main features of the Cristo'Control2

- Automatic management of the operating modes.
- Regulation of the thermal equipment: chiller or heat pump, dry coolers, valves, pumps,...
- Management of the dry coolers in free cooling and the energy recovery on chillers or heat pumps.
- Optimizing the use of the STL.
- Thermal and electrical measurements with temperature probes, sensors, flow and consumption meters.
- Reporting of alarms, defaults, state of equipment and operating parameters by SMS, email and to the BMS (by Modbus or other protocol in option such as LON, BACnet,...).
- Local installation monitoring with touch screen and remote monitoring thanks to its communication features (ADSL, WAN, 3G).

The Auto-Adaptative management module CRISTOPIA exclusivity. Daily optimization using the energy stored in the STL promoting its discharge whatever the conditions and the current season. Predictive calculation of the daily cooling demand based on the elements of the Cristo'Control2 records. Permanent adaptation of the installation in conformity with the cooling demand in order to maximize the use of the STL energy.



Cristo'Control2: control and monitoring of the full system

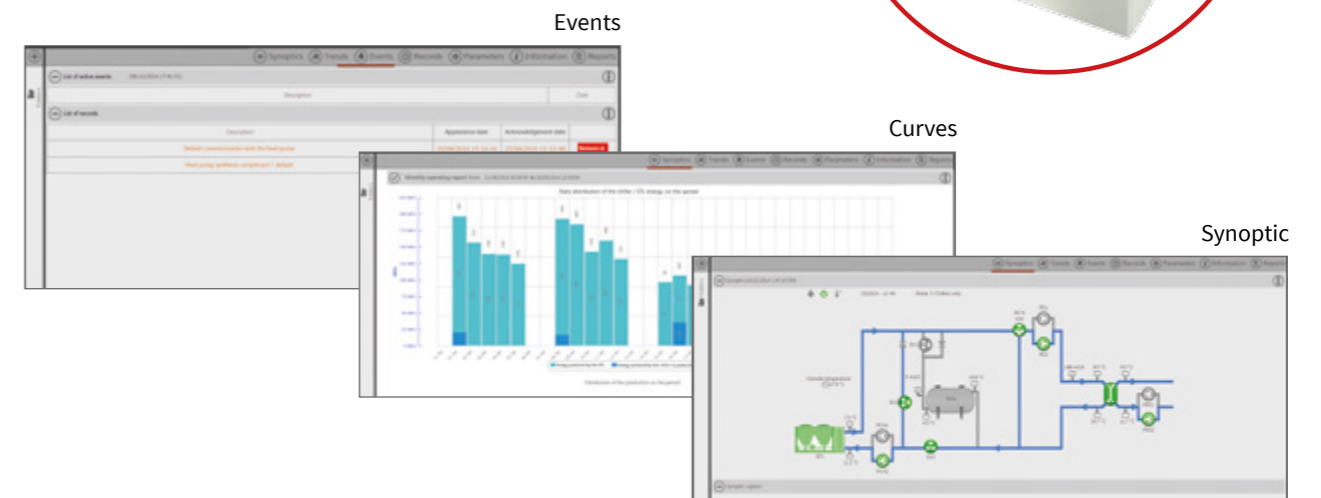
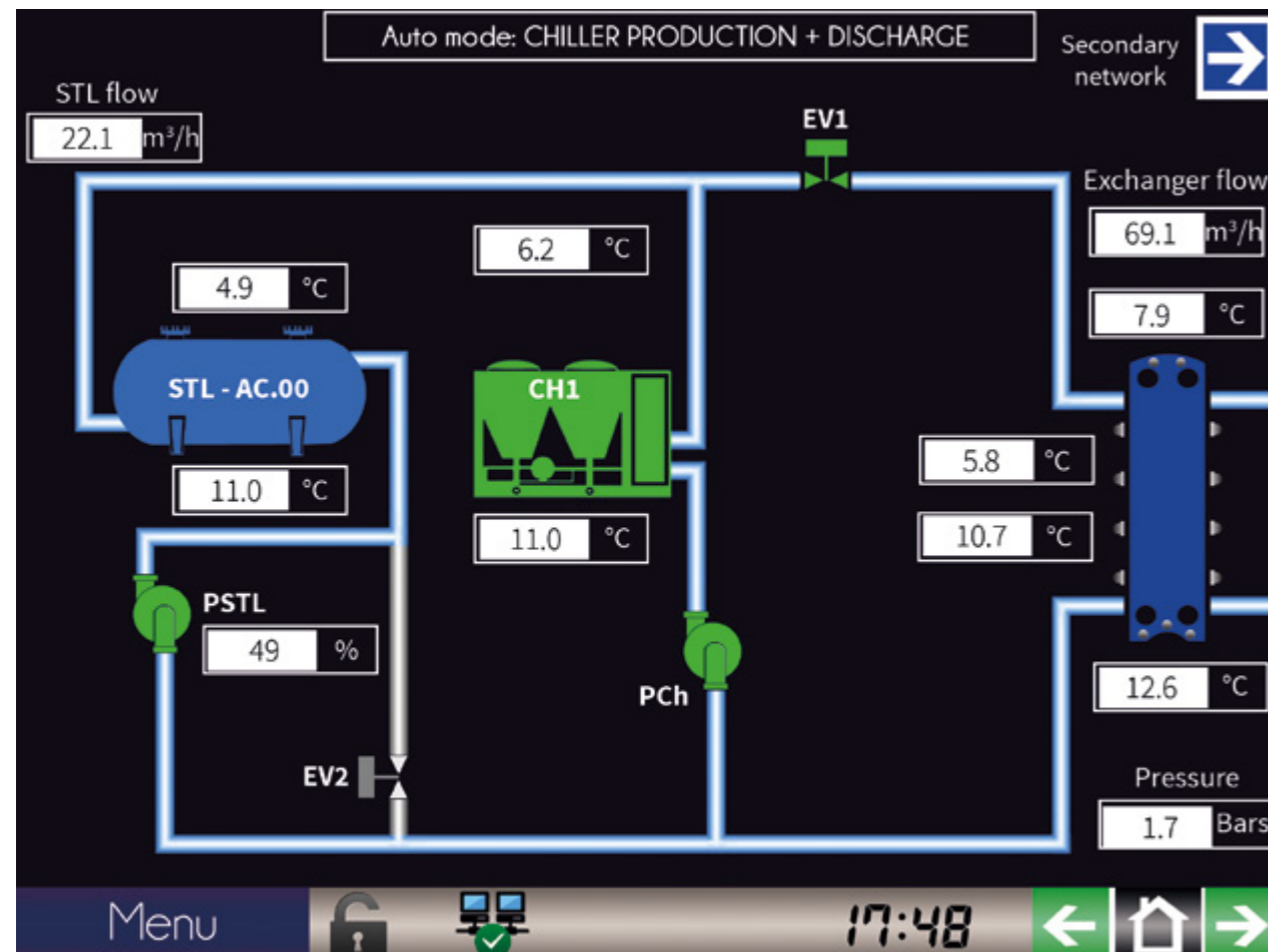

Service contract: support, follow-up, monitoring and energy report

Premium service contract:

- Spare part warranty: during the contract period,
- Hotline: support and customized follow-up,
- Support: analysis and advice on the installation management,
- Maintenance support: anticipation and analysis of your maintenance needs,
- Monitoring: full verification of the equipment and the energy expenditure.

A team of expert engineers advise and support you daily. Thanks to regular monitoring and follow-up you can optimize the operation of your cooling installation with a STL Thermal Energy Storage system. We also offer additional services (training, on-site interventions, evolution of your installation). If you want to know more about our services please contact us.

Engineering: a custom made support

Project design

Analysis, understanding and synthesis of customer needs.

Assistance in project design:

- sizing,
- financial and energy assessment,
- realization of hydraulic layout for each application,
- functional analysis of the control system (Cristo'Control2),
- project by project optimisation,
- eco-environmental improvement (energy savings and CO₂ reduction, TEWI).

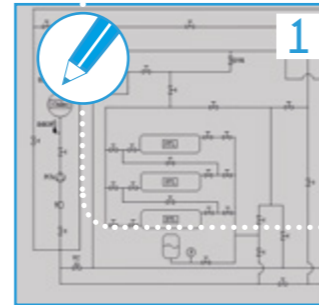

Implementation

Support from time of delivery until STL and equipment devices implementation.

Full support to guide and advise you during the various stages of the installation of the STL.

Advice and technical validation of the complementary components.



Commissioning

Commissioning is ensured on site by our engineers. The main steps are:

- verification of the equipment connection to the Cristo'Control2,
- Cristo'Control2 configuration,
- the start-up and tuning of the installation,
- linking the Cristo'Control2 to the www.cristocontrol.com monitoring Website,
- the report to the BMS,
- training on the use of the Cristo'Control2.



Operation: monitoring and services

The remote operation control of the installation monitored by the Cristo'Control2 allows:

- the transfer of alarms, defaults, equipment states and operating parameters to the BMS and remote monitoring (mail, SMS,...) thanks to its communication features (ADSL, WAN or 3G),
- a real-time monitoring with synoptic, events, curves and operation reports,
- control and optimization of the performances,
- hotline support for management of the installation,
- the opportunity to take advantage of custom made services.

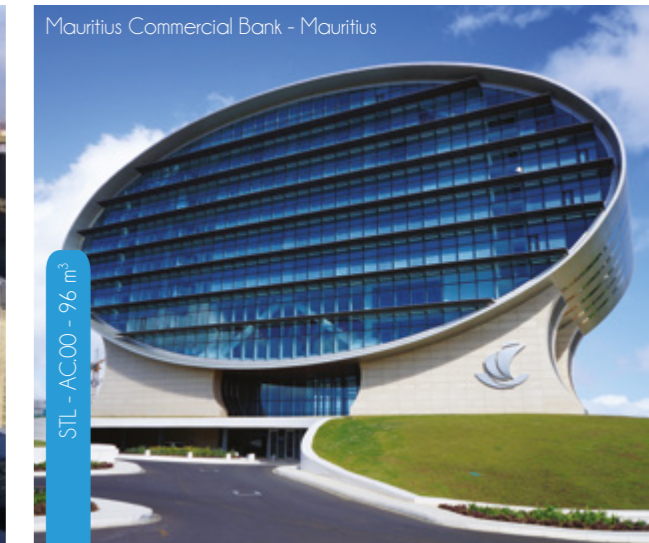
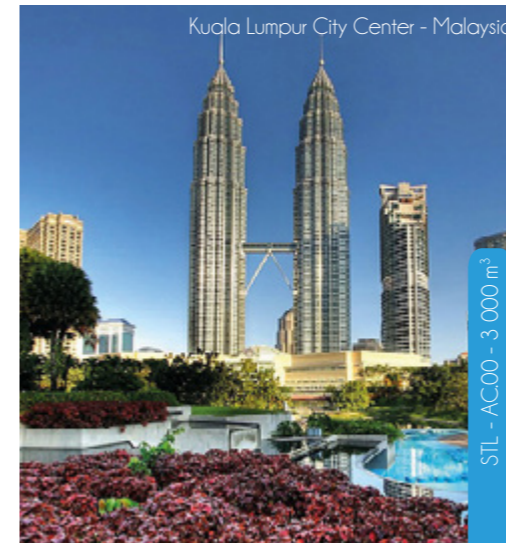



A CIAT Group Company

info@cristopia.com

www.cristopia.com / www.cristocontrol.com

78 chemin du Moulin de la Clue - 06140 Vence - France
Phone: +33 (0)4 93 58 40 00 - Fax: +33 (0)4 93 24 29 38

This document is purely for commercial use and is in no way contractual. CRISTOPIA's Policy is to constantly seek to improve our products and we therefore hereby reserve the right to modify at any time and without prior notice any technical, functional or aesthetic features of our products and services.