



MELODY2

Cassettes



*Perfectly integrated,
the cassettes adapt to
aesthetic, financial
and material constraints*

*Rated cooling capacity: 1.5 to 8.7 kW
Rated heating capacity: 1.3 to 11.6 kW*



USE

The **MELODY 2** cassette is a non-independent air handling terminal unit installed in suspended ceilings, which combines low cost installation and the operating advantages of central

hot/chilled water production with individual temperature controls in each room.

RANGE

The MELODY2 range of cassette type fan coil units comprises 6 sizes which cover flow rates from 360 to 1450 m³/h and meet the most stringent sound level requirements.

2 models:

- Compact cassette 600 x 600, type 61 - 62 - 63.
- Large cassette 900 x 900, type 92 - 93 - 94.

MELODY 2 cassettes are available in 3 versions:

- A 2-tube system, with heating or cooling mode.
- A 2-tube + 2-wire system, with cooling + electric heating or heating/cooling + electric heating.
- A 4-tube system, with heating and cooling mode.

The MELODY 2 cassettes are available either with a 3-speed AC motor or a variable speed EC motor that meet the new building energy performance objectives.

OPERATING PRINCIPLE

The fan takes the air from the room through a grille.

Filtered to be purified, dehumidified, heated or cooled through a chilled or hot water exchanger coil, this air is then discharged

into the room to be air conditioned through 4 swivel blades so as to obtain a maximum increase of the air stream and ensure the diffusion by Coanda effect.

TECHNICAL DESCRIPTION

Return/supply air grille

- Fits perfectly within the suspended ceiling tile dimensions.
- Diffuser colour: Grille and frame: pure white (RAL 9010) and deflectors: signal white (RAL 9003).
- The manual deflectors are adjustable (2 positions) allowing air diffusion throughout the room.

Water coil (2-tube or 4-tube system)

- Galvanised steel sheet.
- Copper tubes, aluminium fins.
- Partial draining and air bleed valve.
- Rated pressure: 14 bar.
- Minimum water inlet temperature: 5 °C.
- Maximum water inlet temperature: 70 °C in 2-tube systems and 80 °C in 4-tube systems.

Electrical heater (2-tube system + electric mode)

- Heating element, stainless steel tubes, inserted in the finned block.
- 2 temperature limiter thermostats (1 auto + 1 manual).

Condensate drain pan

- A condensate drain pan in expanded polystyrene, covered with a waterproof film.
- Recovery is provided by a drain pump equipped with a safety float and mounted on anti-vibration mounts.
- The auxiliary pan is supplied as a standard accessory to recover the valve condensates.

Fan motor assembly

■ AC motor

3-speed motor

- Closed type, with protected shaft.
- Permanent capacitor in the electrics box.
- Automatic heat protection with opening as standard.
- Resilient mounts.
- 230 V-50/60 Hz single-phase power supply.
- Reduced consumption.

■ HEE motor

0 -10 V variable speed motor

- Brushless alternating current (BLAC) technology offering more linear torque progression and a lower operating sound level than brushless direct current (BLDC) motors.
- Sealed, tropicalised with protected well.
- Ball bearings.
- Internal automatic overload protection on the winding as standard.
- Resilient mounts.
- 230 V - 50/60 Hz single-phase power supply.

■ Fan

- Balanced centrifugal impeller with airfoil blades.
- Polymer impeller.

Air filter

- Located on the detachable grille, easy to remove without dismantling.
- Washable polypropylene filter, with efficiency class EU1 (EN13779).

Casing

- Galvanised steel sheet.
- Thermal and acoustic insulation of the internal surfaces.
- Pre-cut (Ø 70 mm for size 600 and Ø 100 for size 900). Pre-cut Ø 150 mm on the side for supply air into the adjacent room.

Electrics box

- Large ABS electrics box with a hinge to keep it open and screw closure.
- IP20 Index of Protection.
- Terminal block on DIN rail in accordance with EN 50022, 7.5 mm deep.
- Junction block located with tension clamp. Cross section 0.5 to 2.5 mm².
- Cable routing for customer connections.

Accessories (available separately)

- Resilient mounts.
- 2-way or 3-way valve kit with bypass and 230 V on/off actuator.
- 2-way or 3-way valve kit with bypass and 24 V 3-point actuator.
- RTR-E & V30 thermostat (AC version only).
- V300 and V3000 control unit kit.

DIMENSIONS

Size 600

Unit without valves

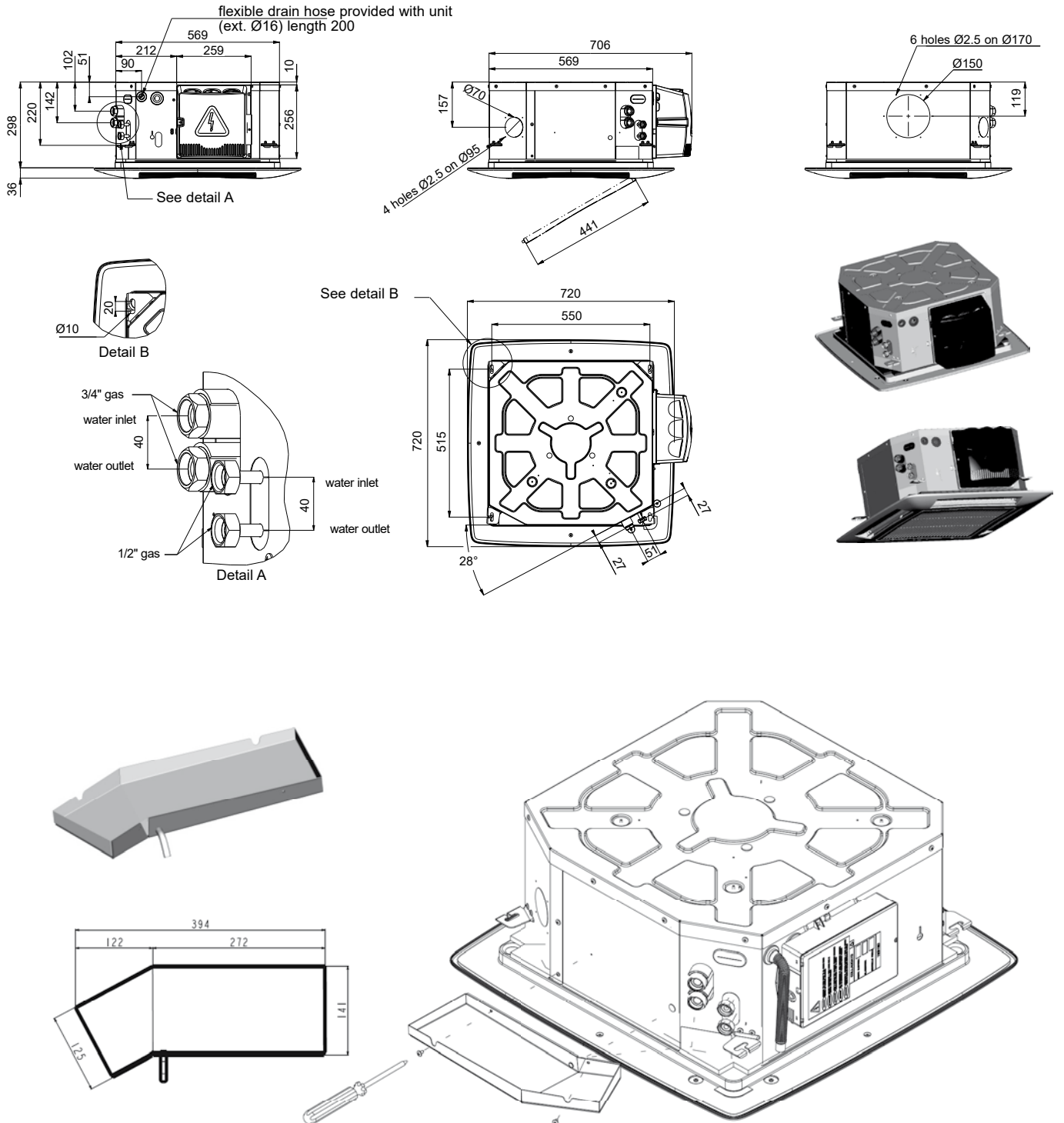

Size 900

Unit without valves

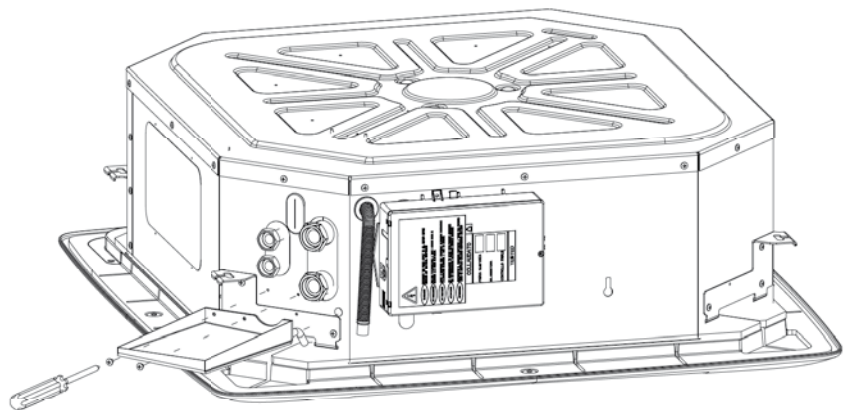
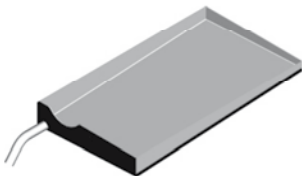
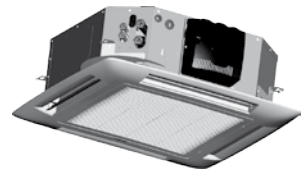
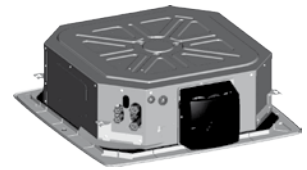
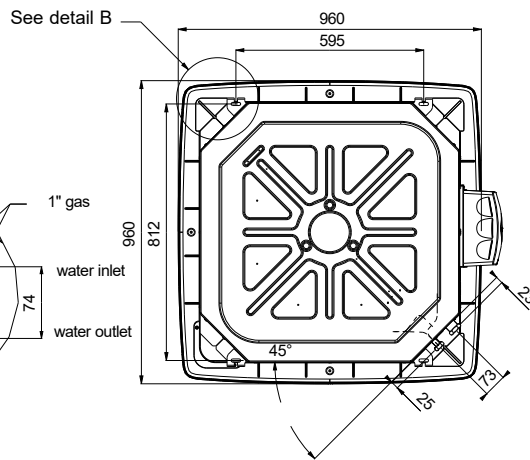
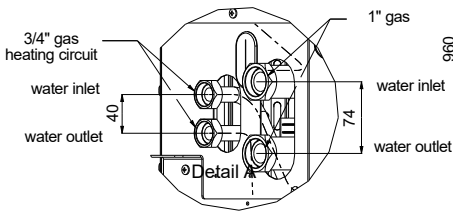
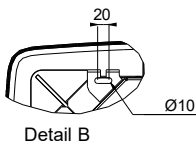
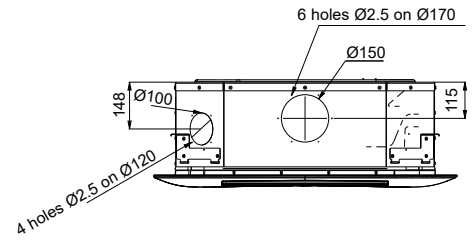
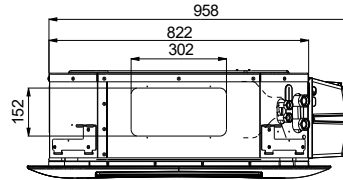
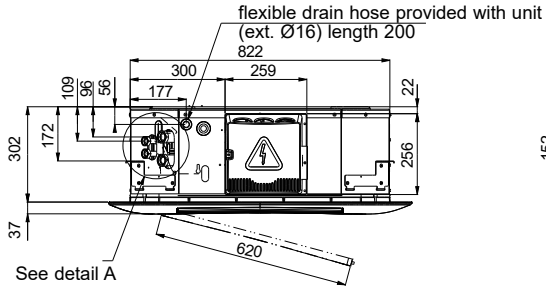

AC MOTOR PERFORMANCE

2-tube

Size	Speeds	Air flow rate m ³ /h	Heating capacity W	Pressure drop (heating) kPa	Cooling capacity		Pressure drop (cooling) kPa	Sound power level L _w dB(A)	Sound pressure level LP* dB(A)	NR *
					Total W	Sensible W				
61 AC	1	660	2 740	12	2 330	1 950	11	49	40	36
	2	450	2 170	8	1 740	1 460	7	41	32	28
	3	360	1 920	7	1 530	1 280	6	37	28	25
62 AC	1	735	3 680	13	3 960	3 010	15	53	44	40
	2	505	3 150	10	2 860	2 161	9	47	35	31
	3	320	1 940	5	1 860	1 410	5	35	26	20
63 AC	1	900	5 280	19	4 640	3 570	20	57	48	43
	2	625	3 920	12	3 460	2 640	12	48	39	34
	3	485	3 160	8	2 770	2 110	8	42	33	28
92 AC	1	980	6 840	23	6 030	4 680	24	49	40	35
	2	720	5 080	14	4 410	3 440	13	40	31	26
	3	530	3 800	9	3 330	2 580	8	35	26	21
93 AC	1	1160	8 510	15	7 130	5 370	12	54	45	40
	2	825	6 260	10	5 430	4 030	8	46	37	32
	3	500	3 850	5	3 680	2 660	5	38	29	22
94 AC	1	1450	10 280	18	8 540	6 400	22	59	50	45
	2	1080	7 950	11	6 430	4 810	13	52	43	38
	3	600	4 380	5	4 020	2 950	6	40	31	25

4-tube

Sizes	Speeds	Air flow rate m ³ /h	Heating capacity W	Pressure drop (heating) kPa	Cooling capacity		Pressure drop (cooling) kPa	Sound power level L _w dB(A)	Sound pressure level LP* dB(A)	NR *
					Total W	Sensible W				
61 AC	1	660	1 670	30	1 970	1 840	15	49	40	36
	2	450	1 270	19	1 490	1 370	9	41	32	28
	3	360	1 090	15	1 340	1 180	8	36	28	25
62 AC	1	735	5 460	21	3 340	2 620	13	53	44	40
	2	505	4 400	15	2 670	2 050	9	47	35	31
	3	320	3 100	9	1 980	1 490	6	35	26	20
63 AC	1	900	5 800	24	3 950	3 250	17	57	48	43
	2	625	5 000	19	3 180	2 550	11	48	39	34
	3	485	4 320	15	2 530	2 040	8	42	33	28
93 AC	1	1160	10 040	12	6 580	5 080	25	54	45	40
	2	825	7 790	8	4 930	3 780	15	46	37	32
	3	500	5 280	5	2 960	2 310	7	38	29	22
94 AC	1	1450	12 770	18	7 490	5 890	32	59	50	45
	2	1080	10 070	12	5 970	4 640	22	52	43	38
	3	600	6 430	7	3 140	2 530	7	40	31	25

EUROVENT conditions

Cooling mode: (2-tube & 4-tube): inlet air temperature: 27 °C/19 °C WB, inlet/outlet water temperature: 7 °C/12 °C

Heating mode: (2-tube): inlet air temperature: 20 °C, inlet/outlet water temperature: 45 °C/40 °C

Heating mode: (4-tube): inlet air temperature: 20 °C, inlet/outlet water temperature: 65 °C/55 °C

*Sound pressure level and noise rating values are based on a hypothetical sound attenuation of the room of 9 dB(A).

EC MOTOR PERFORMANCE

2-tube

Size	Voltage V	Air flow rate m ³ /h	Heating capacity W	Pressure drop (heating) kPa	Cooling capacity		Pressure drop (cooling) kPa	Sound power level L _w dB(A)	Sound pressure level L _p * dB(A)	NR *
					Total W	Sensible W				
61 EC	10	660	2 740	12	2 360	1 980	11	49	40	35
	6	450	2 170	8	1 770	1 490	7	40	31	27
	2	360	1 920	7	1 540	1 290	6	36	27	23
62 EC	10	735	3 680	13	3 960	3 010	15	53	44	40
	6	505	3 150	10	2 860	2 161	9	44	35	31
	2	320	1 940	5	1 860	1 410	5	35	26	20
63 EC	10	900	5 280	19	4 640	3 570	20	57	48	43
	6	625	3 920	12	3 460	2 640	12	48	39	34
	2	485	3 160	8	2 770	2 110	8	42	33	28
92 EC	10	980	6 840	23	6 030	4 680	24	49	40	35
	6	720	5 080	14	4 410	3 440	13	40	31	26
	2	530	3 800	9	3 330	2 580	8	35	26	21
93 EC	10	1160	8 510	15	7 130	5 370	12	54	45	40
	6	825	6 260	10	5 430	4 030	8	46	37	32
	2	500	3 850	5	3 680	2 660	5	38	29	22
94 EC	10	1600	11 030	31	18	7 160	27	61	52	47
	6	1080	7 950	11	6 490	4 860	13	52	43	38
	2	600	4 380	7	4 050	2 980	6	40	31	25

4-tube

Sizes	Voltage V	Air flow rate m ³ /h	Heating capacity W	Pressure drop (heating) kPa	Cooling capacity		Pressure drop (cooling) kPa	Sound power level L _w dB(A)	Sound pressure level L _p * dB(A)	NR *
					Total W	Sensible W				
61 EC	10	660	1 670	30	1 970	1 840	15	49	40	36
	6	450	1 270	19	1 490	1 370	9	41	32	28
	2	360	1 090	15	1 340	1 180	8	36	28	25
62 EC	10	735	5 460	21	3 340	2 620	13	53	44	40
	6	505	4 400	15	2 670	2 050	9	47	35	31
	2	320	3 100	9	1 980	1 490	6	35	26	20
63 EC	10	900	5 800	24	3 950	3 250	17	57	48	43
	6	625	5 000	19	3 180	2 550	11	48	39	34
	2	485	4 320	15	2 530	2 040	8	42	33	28
93 EC	10	1160	10 040	12	6 580	5 080	25	54	45	40
	6	825	7 790	8	4 930	3 780	15	46	37	32
	2	500	5 280	5	2 960	2 310	7	38	29	22
94 EC	10	1600	14 000	20	7 910	6 280	34	61	52	47
	6	1080	10 070	12	6 020	4 640	22	52	43	38
	2	600	6 430	7	3 140	2 530	7	40	31	25

EUROVENT conditions

Cooling mode: (2-tube & 4-tube): inlet air temperature: 27 °C/19 °C WB, inlet/outlet water temperature: 7 °C/12 °C

Heating mode: (2-tube): inlet air temperature: 20 °C, inlet/outlet water temperature: 45 °C/40 °C

Heating mode: (4-tube): inlet air temperature: 20 °C, inlet/outlet water temperature: 65 °C/55 °C

*Sound pressure level and noise rating values are based on a hypothetical sound attenuation of the room of 9 dB(A).

TECHNICAL AND ELECTRICAL CHARACTERISTICS

Coil capacity (litres)

		61	62	63	92	93	94
Standard 2-tube system coil		0.55	1.1	1.1	1.6	2.4	2.4
4-tube coil	Cooling	0.4	1.1	1.1		2.4	2.4
	Heating	0.1	0.6	0.6		1.2	1.2

Coil connection diameter

		61	62	63	92	93	94
Standard 2-tube coil		G 3/4"	G 3/4"	G 3/4"	G 1"	G 1"	G 1"
4-tube coil	Cooling	G 3/4"	G 3/4"	G 3/4"		G 1"	G 1"
	Heating	G 1/2"	G 1/2"	G 1/2"		G 3/4"	G 3/4"

Electrical characteristics * (230 V - 50 Hz / 60 Hz single-phase) – AC fan motor

		Speed	61 AC	62 AC	63 AC	92 AC	93 AC	94 AC
Power input (W)	1		58	58	99	66	88	125
	2		35	34	58	41	61	92
	3		25	17	38	28	34	44
Absorbed current (A)	1		0.27	0.24	0.41	0.3	0.46	0.63
	2		0.17	0.14	0.24	0.17	0.27	0.41
	3		0.12	0.07	0.16	0.12	0.14	0.19

Electrical characteristics * (230 V - 50 Hz / 60 Hz single-phase) – HEE fan motor

		Speed	61 EC	62 EC	63 EC	92 EC	93 EC	94 EC
Power input (W)	2V		29	33	57	25	45	115
	6V		13	14	23	12	23	40
	10V		9	7	13	7	9	11
Absorbed current (A)	2V		0.19	0.27	0.46	0.23	0.4	0.89
	6V		0.1	0.13	0.2	0.12	0.22	0.35
	10V		0.08	0.08	0.12	0.08	0.1	0.12

* Specifications determined for a 230 V +/- 10% - 50 Hz power supply. For operation at 60 Hz, the power input and rotation speed values are generally higher.

Electrical characteristics (240 V - 50 Hz single-phase) – electrical heater

		61	62	63	92	93	94
Electrical power		1500	2500	2500	3000	3000	3000
Absorbed current (A)		6,3	10,4	10,4	12,5	12,5	12,5

Dimensions and weights

		61	62	63	92	93	94
Dimensions** (H x L x D) mm		298 x 706 x 706			302 x 958 x 958		
Grille dimensions (H x L x D)		36 x 720 x 720	36 x 720 x 720	36 x 720 x 720	37 x 960 x 960	37 x 960 x 960	37 x 960 x 960
Weight unit/grille weight		14.8/3	16.5/3	16.5/3	37/5	39.6/5	39.6/5

** With electrics box and without valves

COIL PRESSURE DROPS

2-tube, cooling

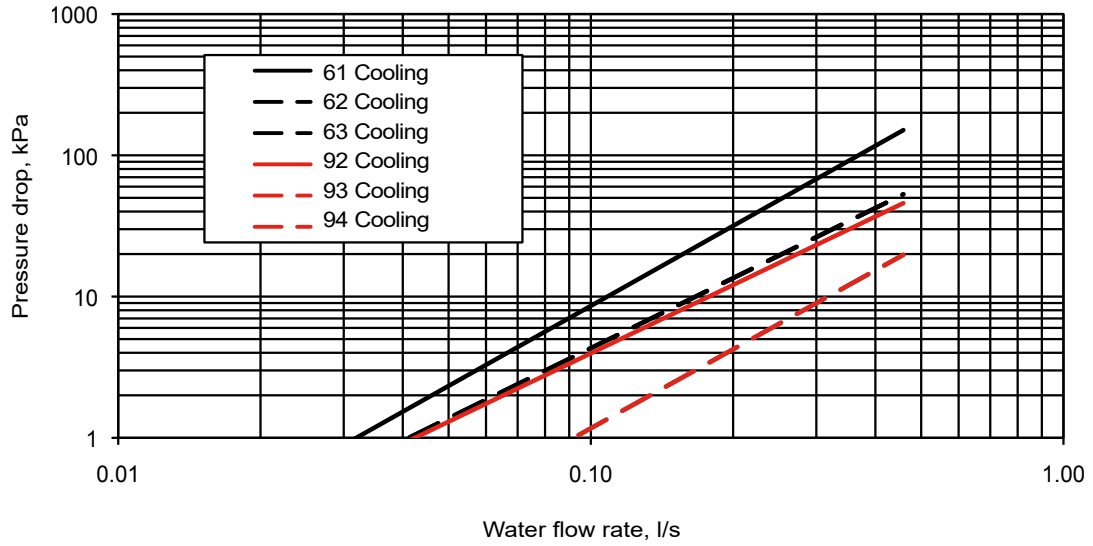

2-tube, heating

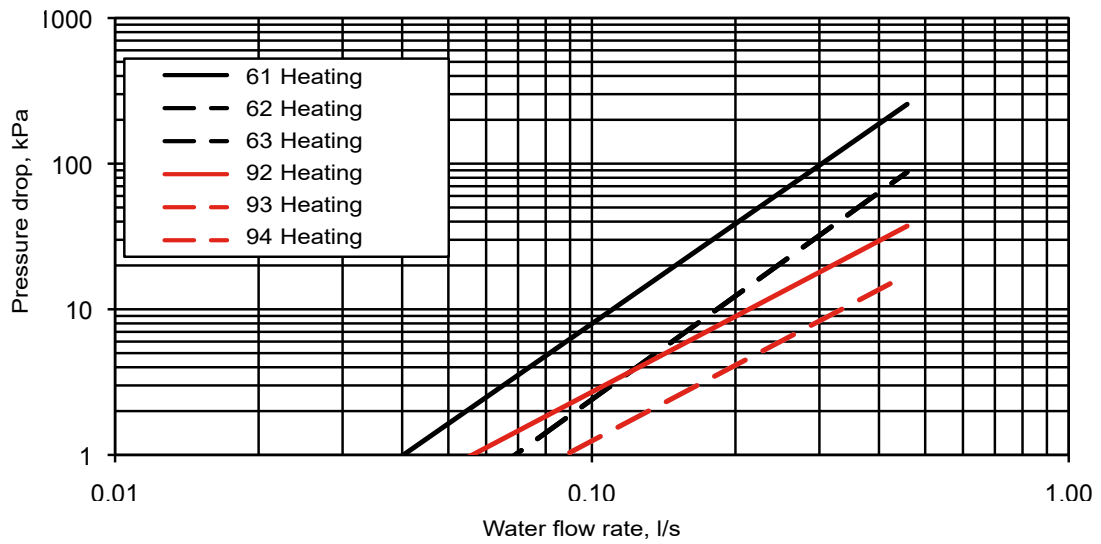

4-tube units, cooling

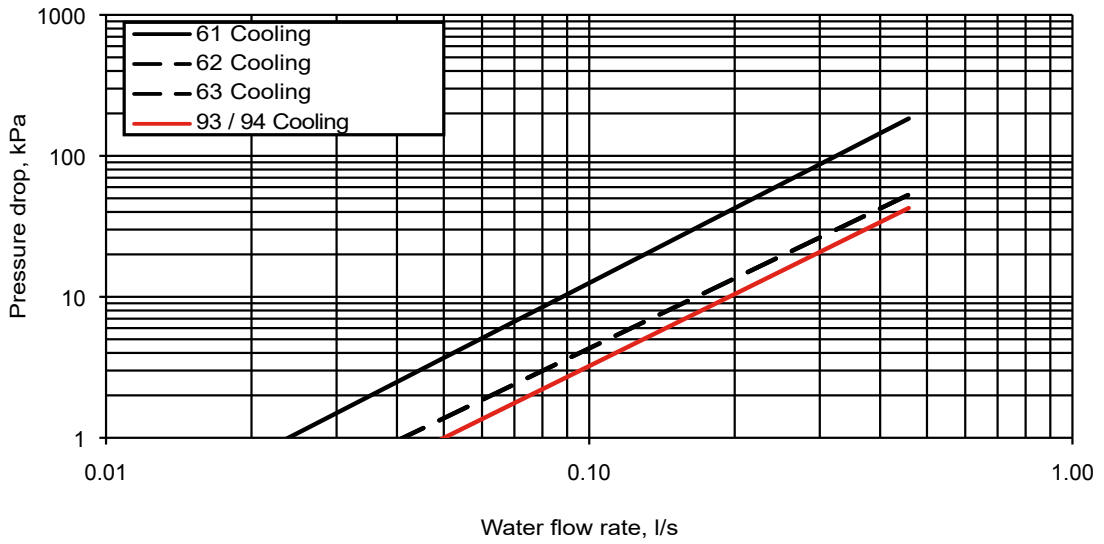

4-tube units, heating

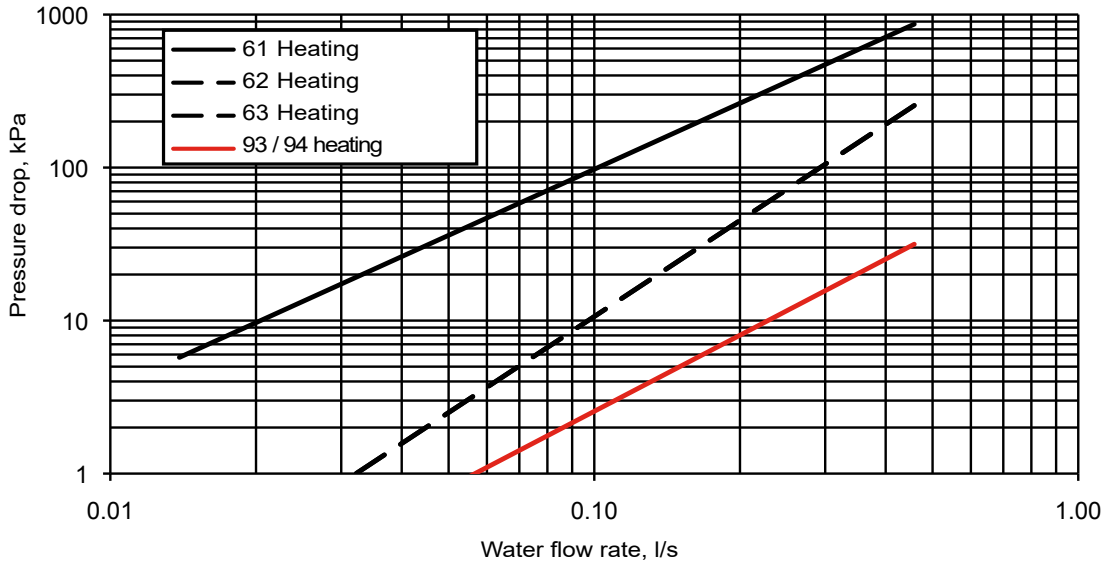

AIR THROW (IN METRES)

MELODY2	Louvres all open		
	High speed	Medium speed	Low speed
61	3.8	3.2	2.7
62	4.0	3.4	2.8
63	4.8	4.1	3.4
92	3.0	2.6	2.1
93	3.4	2.9	2.4
94	4.3	3.7	3.0

Notes:

1. The deflectors were adjusted to use the Coanda effect to obtain an air flow pattern that adheres as closely as possible and parallel to the ceiling.
2. The air throw is defined as the distance at which the air flow speed falls to 0.2 m/s, when the air flow leaves the unit parallel to the ceiling.
3. The values are to be considered as indicative, as they may vary according to the type of ceiling, room dimensions and even the furniture used.

OPERATING LIMITS

Water circuit	Maximum water-side pressure: 1400 kPa (142 mWG)	Minimum inlet water temperature: 5 °C
		Maximum inlet water temperature: 80 °C
Indoor temperature		Minimum temperature: 5 °C
		Maximum temperature: 32 °C for units with electric heaters
Power supply	Nominal operating limits	230 V - 50/60 Hz single-phase
		Min. 207 - Max 253 V for units without electric heaters
		Min. 216 - Max 244 V for units with electric heaters

This document is not legally binding. As part of its continuous drive to improve its equipment, CIAT reserves the right to make any technical modifications without prior notice.
Ref.: NA 19.743 A

Head office

700 Avenue Jean Falconnier - B.P. 14
01350 - Culoz - France
Tel.: +33 (0)4 79 42 42 42
Fax: +33 (0)4 79 42 42 10
www.ciat.com



CIAT Service

Technical support: 0 892 05 93 93 (€0.34/min)
Spare parts: 0 826 96 95 94 (€0.15/min)
pdrfrance@ciat.utc.com - PDRGarantie@ciat.fr

